

# PANTHER T9R



**PAYLOAD**  
17,637 lb • 8,000 kg



**SPEED**  
8.1 mph • 13 km/h



**CAPACITY**  
6.5 yd<sup>3</sup> • 5.0 m<sup>3</sup>



## ENGINE

Make/Model/Type	Caterpillar C4.4 Diesel engine	
Emission Level	EPA Tier 4 Final/ EU Stage V	
Max Power Output	201 HP @ 2200 rpm	150 kW @ 2200 rpm

## TRANSMISSION

Hydrostatic variable displacement pumps and motors

## UNDERCARRIAGE

Track Type	Metal-embedded rubber track (MERT)	
Track Width	27.6 in	700 mm
Ground Clearance	15.2 in	387 mm
Ground Pressure		
without load	3.0 psi	21 kPa
with load	5.3 psi	37 kPa

## BRAKE

Service Brake	Wet Multiple Disk Brakes
---------------	--------------------------

## PERFORMANCE

Payload	17,637 lb	8,000 kg
Travel Speed	8.1 mph	13 km/h
Dump Body Capacity		
Struck	5.0 yd <sup>3</sup>	3.8 m <sup>3</sup>
Heaped	6.5 yd <sup>3</sup>	5.0 m <sup>3</sup>
Operating Weight	23,717 lb	10,760 kg
Maximum Gradeability		
Uphill/Downhill	27%	15°
Side hill	27%	15°

## FLUID CAPACITIES

Diesel Fuel	53 gal (US)	200 l
DEF / AdBlue <sup>†</sup>	5 gal (US)	19 l

## ELECTRICAL SYSTEM

Voltage	12 V
Alternator Capacity	150 A
Battery Capacity	1150 CCA (two)

**Pinoth**<sup>®</sup>

# EQUIPMENT

## STANDARD EQUIPMENT

### Operator environment

Spacious wide cab – 1 person
Tilt and telescopic steering wheel
Foot throttle pedal
Operator seat with suspension and adjustments
Air conditioning
Adjustable temperature, fan control and fresh air intake
Three-point seat belt
Front and rear wipers with adjustable speeds
Windshield washer
Two exterior mirrors (right-side remotely adjustable)
Main display 4.3 in (111 mm)

### Safety

Rear and side-view cameras
Inclinometer built-in display's with adjustable alarms
Parking brake condition on seat belt and armrest
Side window emergency exit
ROPS ISO 3471
Back-up alarm
Horn
First aid kit
Fire extinguisher

### Electrical and Lighting

Batteries maintenance-free (two)
Working lights, LED (two front, one rear)
Battery disconnect switch

### Other

Pressurized hydrostatic oil tank
Lockable compartments for fluids and batteries
D-ring for transportation (two)
Lockable door
Spare parts catalog
Operating and maintenance manuals

## OPTIONAL EQUIPMENT

Bluetooth Radio, USB and AM/FM	FOPS ISO 3449	Front brushguard
Flashing LED beacon light	Engine block and hydraulic oil heaters	Emergency driving system
Trainer seat	Engine coolant heater	

# DIMENSIONS

<b>A</b>	116.3 in	2,955 mm	<b>L</b>	58.9 in	1,495 mm
<b>B</b>	97.8 in	2,485 mm	<b>M</b>	83.9 in	2,131 mm
<b>C</b>	70.3 in	1,785 mm	<b>N</b>	176.5 in	4,482 mm
<b>D</b>	15.2 in	387 mm	<b>O</b>	91.2 in	2,316 mm
<b>E</b>	27.6 in	700 mm	<b>P</b>	111.2 in	2,825 mm
<b>F</b>	206.5 in	5,246 mm	<b>r1</b>	117.7 in	2,990 mm
<b>G</b>	177.1 in	4,498 mm	<b>r2</b>	110.7 in	2,811 mm
<b>H</b>	150.0 in	3,811 mm	<b>a1</b>	23°	
<b>I</b>	47.1 in	1,204 mm	<b>a2</b>	33°	
<b>J</b>	112.3 in	2,853 mm	<b>a3</b>	60°	
<b>K</b>	40.0 in	1,004 mm			

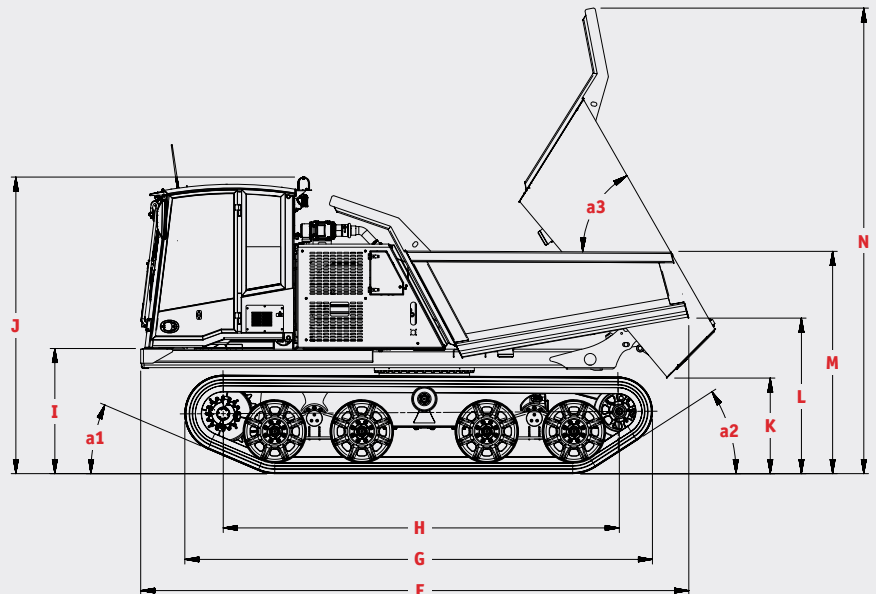
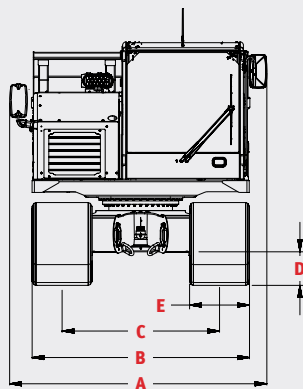
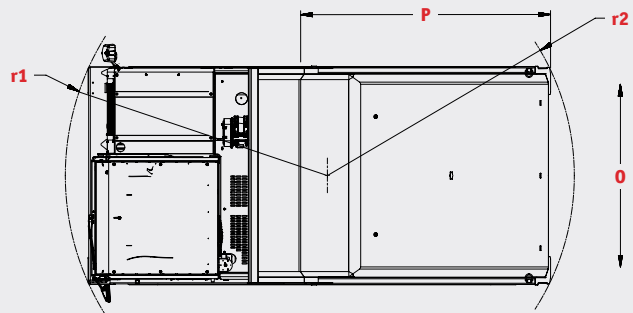

PRINOTH Ltd., 1001 J.-A. Bombardier Street, Granby QC J2J 1E9, CANADA  
 Service: 450-776-3663 after.sales.service.na@prinoth.com  
 Parts: 1-866-776-3636 parts.na@prinoth.com  
 Sales: 450-776 3600 sales.na@prinoth.com

